

# Pneumatic Tacker

## 380/16-400 OC

The light but powerful tacker of the BeA 400 series uses staples type 80/380 in leg lengths from 5/16" to 5/8". The 380/16-400 OC stapler flares the staple legs outward as they penetrate the material being fastened. The outward clinch nose can be adjusted to control the amount of leg flare. The low air consumption, long service life and ease of maintenance make this tool a cost saver. The bottom-loading magazine allows for quick and easy loading.

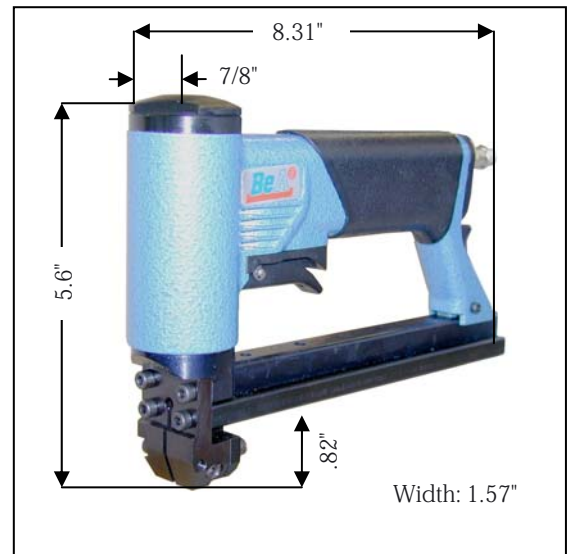

### Popular applications:

Fastening ticking fabric to foam rubber box spring borders.  
Textile-stapling layers of fabric together in pattern cutting.

### Technical Data

Model:	<b>380/16-400 OC</b> Outward clinch
Part number:	120000024
Loading type:	bottom loading
Staple type:	80, 380
Magazine capacity:	157
Standard load, strips x staples/strip:	1 x 125 Type 80 / 1 x 150 Type 380
Operating pressure:	75-90 P.S.I.
Maximum air pressure:	90 P.S.I.
Air consumption:	.01 cu. ft./cycle @ 90 P.S.I.
Recommended hose I.D.:	ø 3/8"
Weight:	2.26 lbs.

Items supplied with tool: Operating instructions, spare parts list & service instructions.

Subject to technical modifications.

### Accessories:

Part number	Description
14403330	Remote firing valve
14403535	Stationary mounting fixture

All BeA pneumatic tools can be jig mounted.  
We supply the necessary accessories.



This tool conforms to the EC Directive  
for Machinery (89/392 EWG)

# Pneumatic Tacker 380/16-400 OC



BeA Fasteners U.S.A.  
2100-120 Fairfax Road  
Greensboro, NC 27407  
Phone: (336) 510-4232  
Fax: (336) 510-4233

## Staple types 80/380

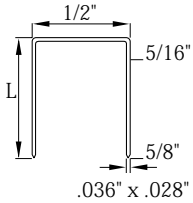

Description	L = Length inches
80/04 NK	5/32"
80/05 NK	3/16"
380/06 NK	1/4"
380/08 NK	5/16"
380/10 NK	3/8"
380/12 NK	1/2"
380/14 NK	9/16"
380/16 NKS	5/8"

Other lengths and finishes are also available on request.

### Fastener nomenclature:

NK = Galvanized steel  
NKS = Galvanized steel, high carbon  
BK = Brite steel  
BKS = Brite steel, high carbon

HZ = Resin coated  
NR = Stainless steel  
DP = Divergent point